

# MOBILE K A A B TOILETTE



MOBILE DRY TOILETS

 Convert  
Green

 Kaab  
Toilettes mobiles

# How it works

Liquids and solids are separated with the conveyor belt.  
The slightest draft dehydrates the solids and ensures the odorless system.

A light breeze is enough to spin the extractor and ventilate the device.

The device warms up with the sun, the indoor air flow speed up.

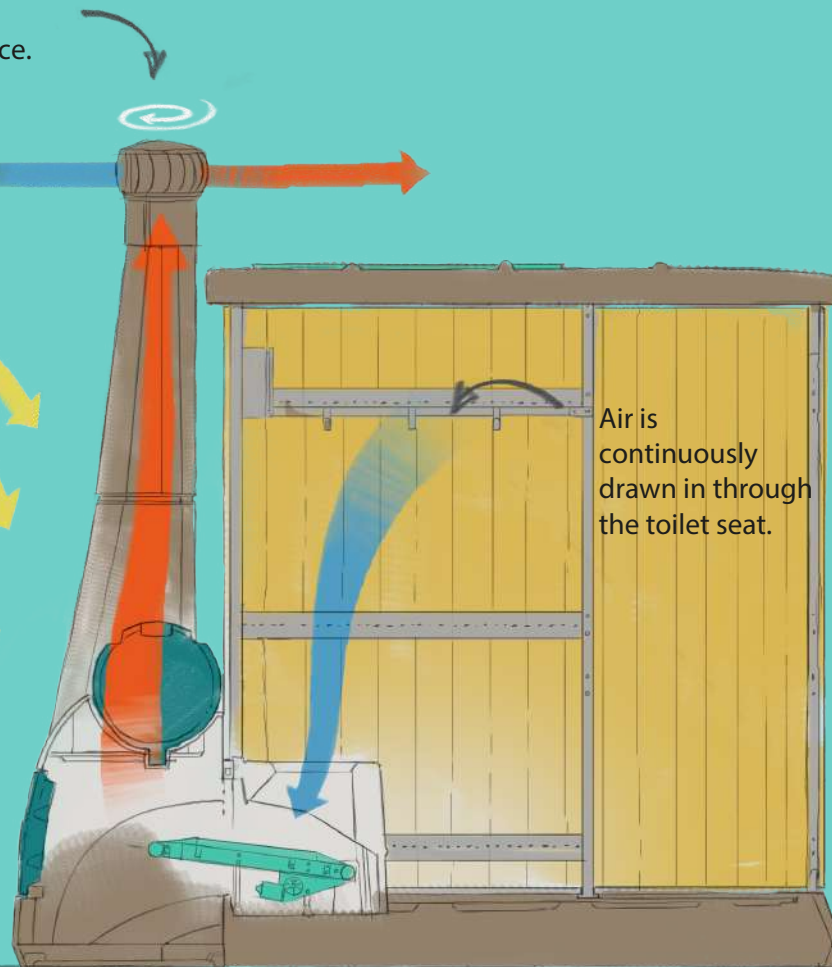

Air is continuously drawn in through the toilet seat.

## Continuous air flow

- Reduces the volume of waste (up to 90%)
- Kills pathogens and facilitates aerobic bacteria
- Ensures odor-free operation
- No addition of straw or sawdust

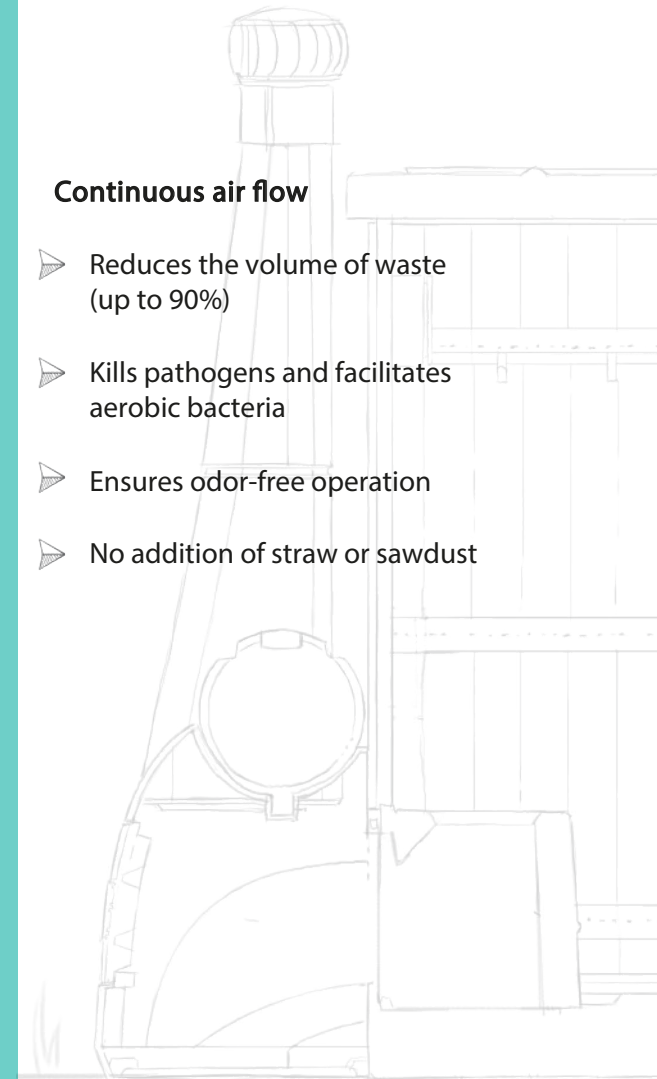

# Transport your Bumper

With a crane truck or a forklift...

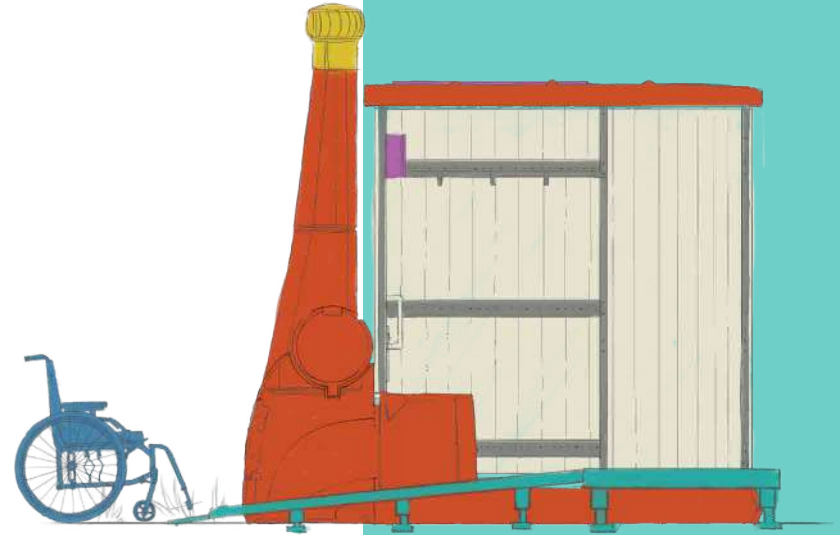
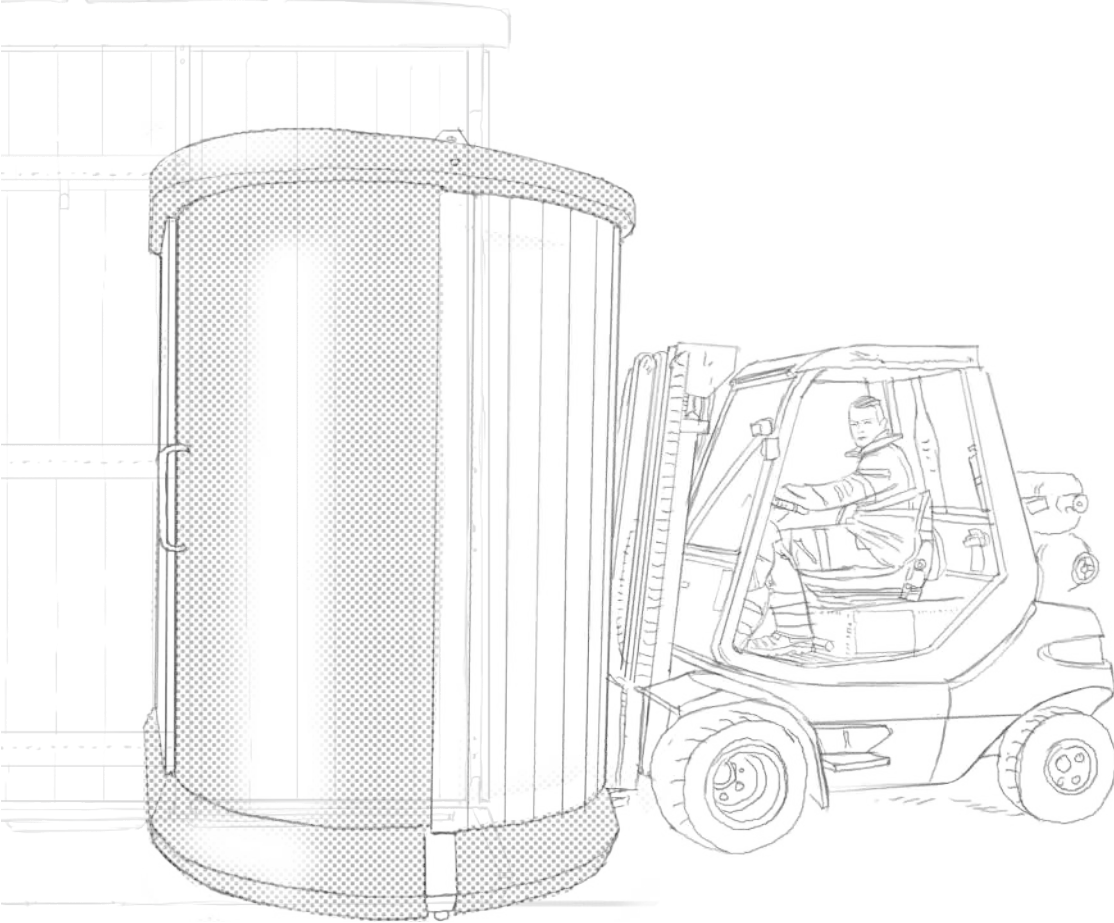

▶ A disabled access ramp is added

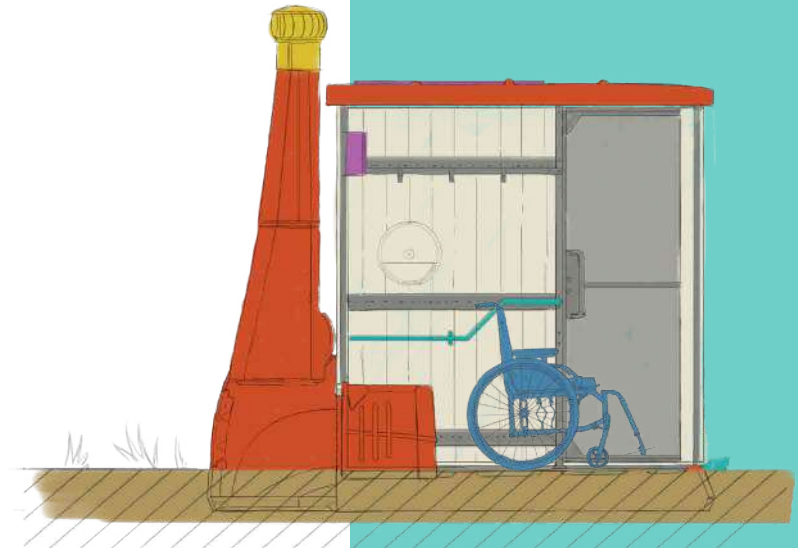

▶ Or set it up in a 24 cm excavation

# Equipment

## Solar panel

The bumper is equipped with a solar panel and a battery to supply the lighting, the conveyor belt and the control panel.

## Electronic control unit

This unit controls the operation of the device, the conveyor belt and the lighting. The control screen provides access to the passage counter.

## Toilet seat

Anti-vandal.  
Flared shape for maximum hygiene.  
Easy to clean.  
Suit for disabled standard.

## Supavent extractor

ASA impeller, polycarbonate support ring, aluminum shaft, stainless steel bearing.  
Withstands winds of 205 km/h

## Door

The door is equipped with an adjustable automatic return.

## Welcome is a priority !

The bumper meets disabled standards.  
Standard equipment:

- ▶ Stainless steel lifting bar
- ▶ Coat peg
- ▶ Sheet-by-sheet toilet paper dispenser
- ▶ Hydroalcoholic gel dispenser
- ▶ Closing latch with occupancy indicator
- ▶ Automatic door closer
- ▶ Autonomous lighting

# Care and maintenance

## Routine maintenance:

As with every public toilet, daily cleaning is required. The bowl, the floor and possibly the walls are cleaned with water (low or high pressure cleaner), with a brush or a sponge.

A solar panel on the roof ensures Electric autonomy. It must be cleaned regularly and checked if nothing interferes with sunlight.

## Maintenance:

The bottom of the bumper is the urine tank. It holds 500 liters. It should be emptied approximately every 2000 uses. It is possible to visually check the filling level through the maintenance hatch.

For sites with medium or low traffic, a minimum of 1 annual cleaning is recommended.



# Dimensions

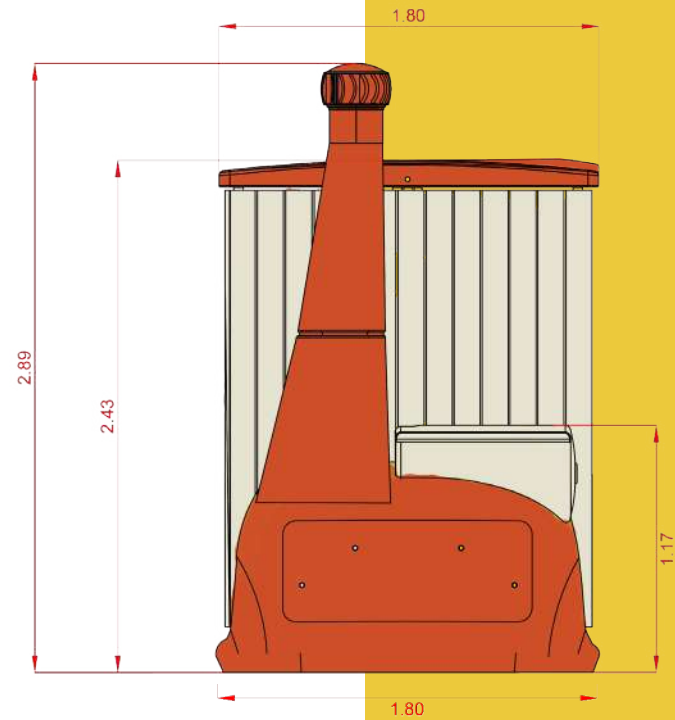
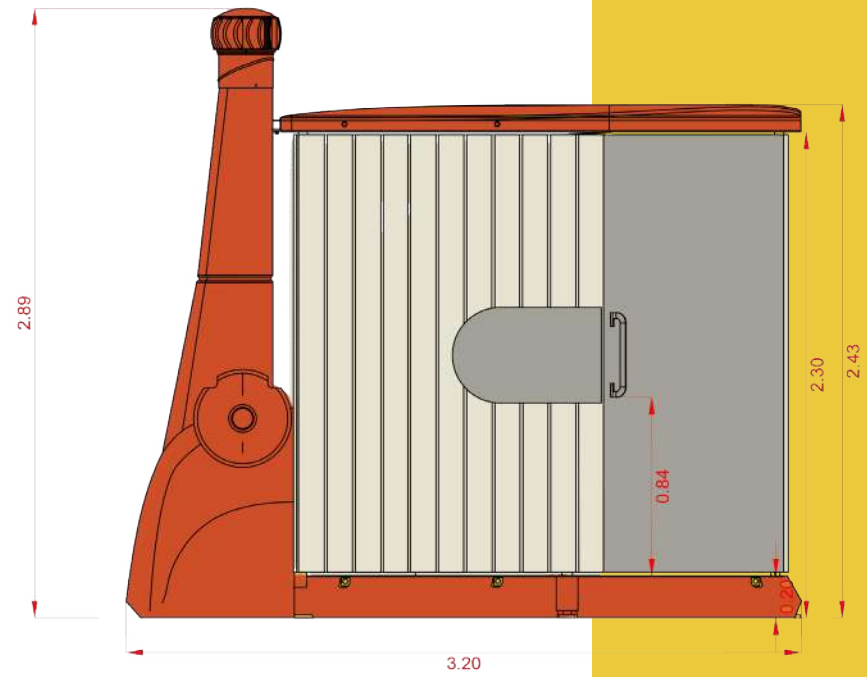
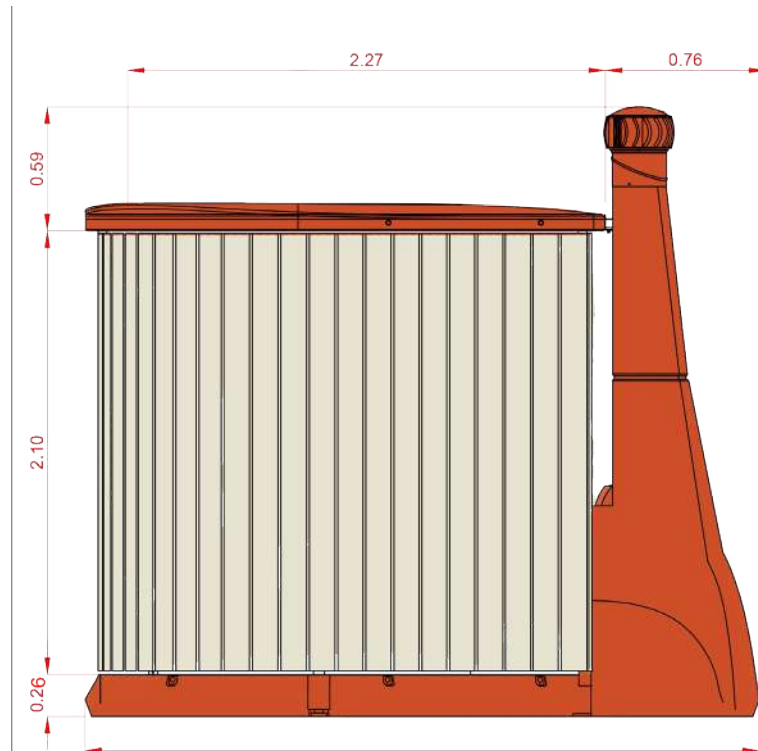

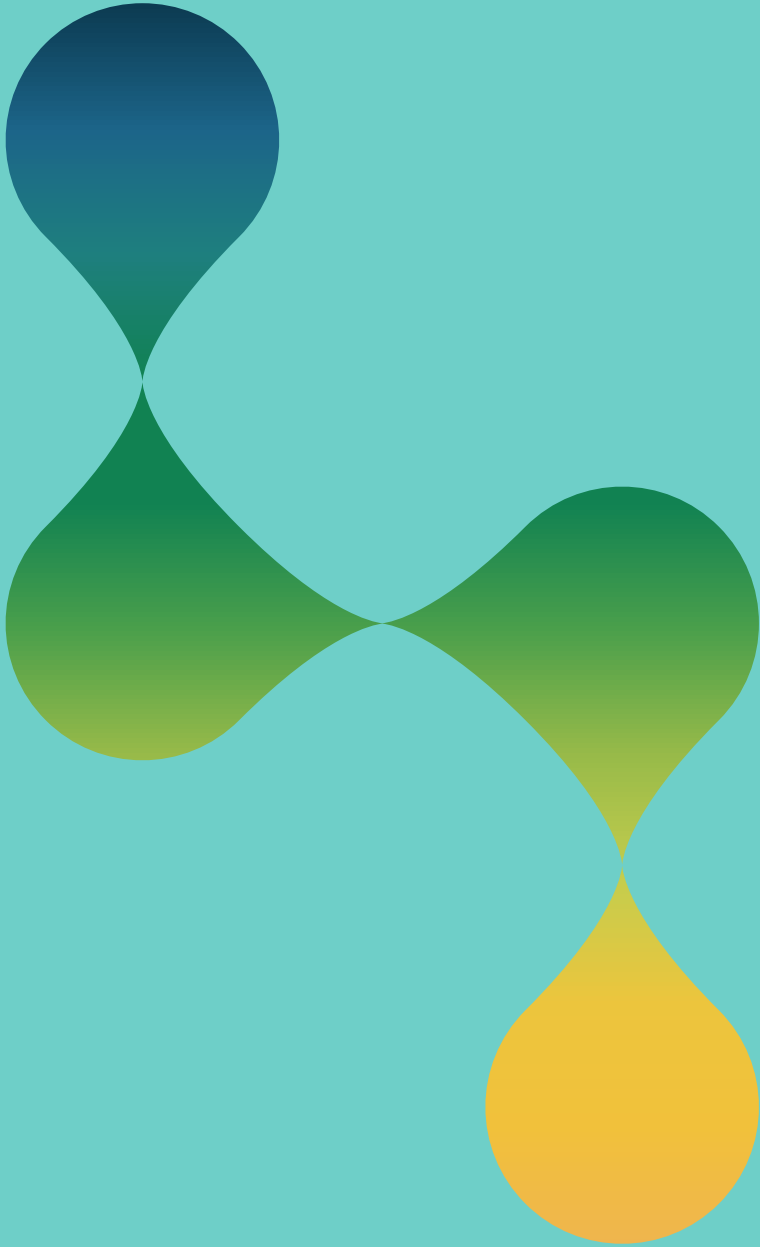

**Convert Green Sagl | Via al Mulino, 22 CH-6814 Cadempino Switzerland  
T +41 79 601 57 50 | [info@convertgreen.ch](mailto:info@convertgreen.ch) | [www.convertgreen.ch](http://www.convertgreen.ch)**